

MP200 SYSTEMS

MP200 Starter System and Licensed Systems – See corresponding [license page](#) for more information:

System	Windows OS Part #	macOS Part #
MP200 System	MP200WSW	MP200WS
MP200 System plus Workflow	MP200WSW-AWF	MP200WS-AWF
MP200 System plus Actigraphy	MP200WSW-ACT	MP200WS-ACT
MP200 System plus Baroreflex	MP200WSW-BRS	MP200WS-BRS
MP200 System plus Developer Bundle	MP200WSW-ENT	n/a
MP200 System plus FaceReader Integration License	MP200WSW-FR	n/a
MP200 System plus Network Data Transfer	MP200WSW-NDT	MP200WS-NDT
MP200 System plus Pressure Volume Loop Analysis	MP200WSW-PVL	MP200WS-PVL
MP200 System plus Scripting	MP200WSW-BAS	MP200WS-BAS
MP200 System plus Vibromyography: 2-channel	VMG102WSW	VMG102WS
MP200 System plus Vibromyography: 4-channel	VMG104WSW	VMG104WS
System Upgrade to MP200 from MP160 or MP150	MP200U-W	MP200U-M

MP200 data acquisition and analysis systems with AcqKnowledge 6 software provide a flexible tool for life science research. All systems are compliant with any Ethernet (UDP) ready 64-bit computer running Windows or Mac (AcqKnowledge 6 or higher required). Record multiple data channels with variable sample rates to maximize storage efficiency at speeds up to 100 kHz per channel. Directly connect the computer to a single MP200 unit via the provided ETHUSB Ethernet adapter, or access multiple MP200s by connecting a switch box to the adapter.

Basic MP200 System includes:

Data acquisition unit: MP200

Transducer module: AMI100D

AcqKnowledge® software license (dual USB keys)

Software Guide (PDF)

Ethernet Connection

ETHUSB Ethernet adapter
 and Ethernet Cable: CBLETH1

Power Supply: AC150A

See also: MP200 Specifications



ACQKNOWLEDGE SOFTWARE

Recommended MP200 configuration

For the best possible performance connect the MP System directly to the ETHUSB Ethernet USB adapter using the included CBLETH1 Ethernet cable. This allows uninterrupted use of the existing Ethernet card for Internet and local area network (LAN) access while using the MP System. **Although it is possible to run multiple MP200 units over a LAN, this solution is not recommended by BIOPAC.** BIOPAC recommends using the ETHUSB adapter and connecting directly between computer and the MP200, or to a switch box and the MP200. (If a computer has an available Ethernet port, a standard Ethernet cable can be used to connect the MP System to the computer.)

AC150A POWER SUPPLY

The 12-volt in-line switching transformer connects the MP unit to the AC mains wall outlet. One transformer is included with each MP System; replacements can be ordered separately. These transformers are specified to satisfy IEC 60601-1 requirements and will accommodate 120-240 VAC (50/60 Hz) mains input.

ISOLATION

Designed to satisfy the following Medical Safety Test Standards affiliated with IEC 60601-1:

- Creepage and Air Clearance
- Dielectric Strength
- Patient Leakage Current

Contact BIOPAC for additional details.



SIGNAL CONDITIONING MODULE COMPATIBILITY

AMI100D	EGG100D	NIBP100E/NIBP100E-HD
BioNomadix Series Wireless Modules	EMG100C/EMG100C-MRI	NICO100C/NICO100C-MRI
CO2100C	EMG100D	NICO100D
DA100C	EOG100C/EOG100C-MRI	O2100C
EBI100C	EOG100D	OXY100E
ECG100C/ECG100C-MRI	ERS100C/ERS100C-MRI	OXY200
ECG100D	ERS100D	PPG100C/PPG100C-MRI
EDA100C/EDA100C-MRI	fEMG100D	PPG100D
EDA100D	HLT100C	RSP100C/RSP100D
EEG100C/EEG100C-MRI	LDF100C	SKT100C/SKT100D
EEG100D	MCE100C	STM100C
EGG100C/EEG100C-MRI		

CLEANING PROCEDURES

Be sure to unplug the power supply from the MP200 before cleaning. To clean the MP200, use a damp, soft cloth. Abrasive cleaners are not recommended as they might damage the housing. Do not immerse the MP200 or any of its components, as this can damage the system. Let the unit air-dry until it is safe to reconnect the power supply.

MP200 SYMBOLOGY

Front panel	
	<p>See MP200 LED STATUS INDICATORS AND DESCRIPTIONS section below for functionality details.</p>
Back panel	
	<p>Power</p> <p>ON Push in to power up the MP200</p> <p>OFF Push again to cut the flow of power to the MP200</p> <p>IMPORTANT! The MP200 does not have a “Hardware Reset” switch like a personal computer does. To reset the MP200 for any reason, turn the MP200 off, wait a few seconds, and then turn it back on.</p> <p>USB-C Function will be enabled in a future software release. It is currently disabled.</p> <p>DC Input Use the DC Input to connect a battery, AC/DC converter or other power supply to the MP200.</p> <ul style="list-style-type: none"> ▪ The MP200 requires 12 VDC @ 1 Amp (minimum), 2 Amp (nominal) ▪ The receptacle can accept a “+” (positive) input in the center of the connector and a “-” (negative) input on the connector housing. <p>Ethernet The MP200 connects to the computer via the Ethernet port, located just below the word Ethernet.</p> <ul style="list-style-type: none"> ▪ Uses a standard RJ-Ethernet connector (100 base T). <p>GPS Allows clock to be synchronized with GPS satellites. Function will be enabled in a future software release. It is currently disabled.</p>
Side panel	
<p>Module connections</p>	<p>The two connector inputs are designed to connect directly to the AMI100D.</p> <ul style="list-style-type: none"> ▪ Analog signals are transmitted through the 37-pin connector (upper right side) ▪ Digital signals are transmitted through the 25-pin connector (lower-right side) and accessed with optically isolated STP100D/STP100D-C and STP-IO (not included)

MP200 LED STATUS INDICATORS AND DESCRIPTIONS

Normal Settings

STATUS LED	MODE	LIGHT STATUS DESCRIPTION
Off	Off	MP200 power off or transitioning to power off state.
Solid Red	Initial Startup/ERROR	Default state of LED. When system powers up, LED will spend some time in this state. This phase during startup should be brief (a few seconds). If LED holds this state for a prolonged period or enters this state after having passed through others, check OLED screen on device as this state also represents fatal error. If this state persists, device almost certainly will require service. OLED screen will report error state if possible, but if OLED is dark, error likely prevents device from writing to screen.
Solid White	Powering Up	After initial power up, device transitions to checking for communication. After device programming has loaded and before device actively seeks connection status, LED passes through this state (may appear bluish).
Flashing Yellow	Waiting for Connection	Device does not detect any connection. During normal startup, device will pass through this state. The device will remain in this state if no connection is detected.
Flashing Blue	Waiting for IP address	When device detects connection, it searches for server that can provide IP address. Upon failure, device will self-assign IP. If device has to self-assign, the unit may persist in this state for about 30 seconds. Software will not be able to detect device until it has an IP address.
Solid Blue	Received IP address	Unit has been given or has assigned itself an IP address. Device should be detectable to AcqKnowledge in this state.
Solid Green	Connected/Idle	Device is locked to an instance of AcqKnowledge and is ready to be configured or to collect data.
Flashing Green	Acquiring Data	Normal acquisition.
Flashing Orange-Yellow	Stimulator output without acquisition	Note that stimulator output may be coincident with acquisition, so flashing green may also be accompanied by signals passing through either or both of analog output channels. Flashing yellow indicates analog output is occurring in the absence of data acquisition.
Slowly Pulsing Blue	Screensaver engaged	To minimize burn in on OLED screen, device will enter a screen saver mode if no communication is set up. Device must change state to disengage screen saver. Establish connection with AcqKnowledge, disconnect/reconnect ethernet cable, or power cycle the device to disengage screen saver.
Flashing White	Updating firmware	Normal status while firmware is being updated (note that “white” may appear bluish as blue component of LED is typically brighter than red and green components). Do NOT disconnect or power off device while in this state! Complete firmware update process may take a few minutes.
Flashing Red-Orange	Warning	Device has detected a problem. Check OLED screen for details. Note that when a problem has been detected, device normally switches back and forth between warning state and indication of state device is in aside from warning. Warnings may be cleared via "MP200 > MP200 Info..." dialog box under "Log" tab.
Flashing Red	Error	Serious error has been detected. See OLED screen for details. State similar to warning but generally indicates much more severe problem.

Alternate Settings

STATUS LED	MODE	LIGHT STATUS DESCRIPTION
Solid Red	Initial Startup/ERROR	Default state of LED. When system powers up, LED will spend some time in this state. This phase during startup should be brief (a few seconds). If LED holds this state for a prolonged period or enters this state after having passed through others, check OLED screen on device as this state also represents fatal error. If this state persists, device almost certainly will require service. OLED screen will report error state if possible, but if OLED is dark, error likely prevents device from writing to screen.
Solid Magenta	Powering Up	After initial power up, device transitions to checking for communication. After device programming has loaded and before device actively seeks connection status, LED passes through this state.
Solid Bright Blue	Waiting for Connection Status/IP address	<ol style="list-style-type: none"> 1. Device does not detect any connection. During normal startup, device will pass through this state. The device will remain in this state if no connection is detected. 2. When device detects connection, it searches for server that can provide IP address. Upon failure, device will self-assign IP. If device has to self-assign, the unit may persist in this state for about 30 seconds. Software will not be able to detect device until it has an IP address.
Solid Sky Blue	Received IP address	Unit has been given or has assigned itself an IP address. Device should be detectable to <i>AcqKnowledge</i> in this state.
Solid Green	Connected/Idle	Device is locked to an instance of <i>AcqKnowledge</i> and is ready to be configured or to collect data.
Flashing Green	Acquiring Data	Normal acquisition.
Flashing Yellow	Stimulator output without acquisition	Note that stimulator output may be coincident with acquisition, so flashing green may also be accompanied by signals passing through either or both of analog output channels. Flashing yellow indicates analog output is occurring in the absence of data acquisition.
Slowly Pulsing Blue	Screensaver engaged	To minimize burn in on OLED screen, device will enter a screen saver mode if no communication is set up. Device must change state to disengage screen saver. Establish connection with <i>AcqKnowledge</i> , disconnect/reconnect ethernet cable, or power cycle the device to disengage screen saver.
Pulsing White	Updating firmware	Normal status while firmware is being updated (note that "white" may appear bluish as blue component of LED is typically brighter than red and green components). Do NOT disconnect or power off device while in this state! Complete firmware update process may take a few minutes.
Flashing Red-Orange	Warning	Device has detected a problem. Check OLED screen for details. Note that when a problem has been detected, device normally switches back and forth between warning state and indication of state device is in aside from warning. Warnings may be cleared via "MP200 > MP200 Info..." dialog box under "Logs" tab.
Flashing Red	Error	Serious error has been detected. See OLED screen for details. State similar to warning but generally indicates much more severe problem.

MP200A-CE DATA ACQUISITION UNIT BLOCK DIAGRAM

The MP200 has an internal microprocessor to control the data acquisition and communication with the computer. There are 16 analog input channels, two analog output channels, 16 digital channels that can be used for either input or output, and an external trigger input. The digital lines can be programmed as either inputs or outputs and function in 8 channel blocks. Block 1 (I/O lines 0 through 7) can be programmed as either all inputs or all outputs, independently of block 2 (I/O lines 8 through 15).

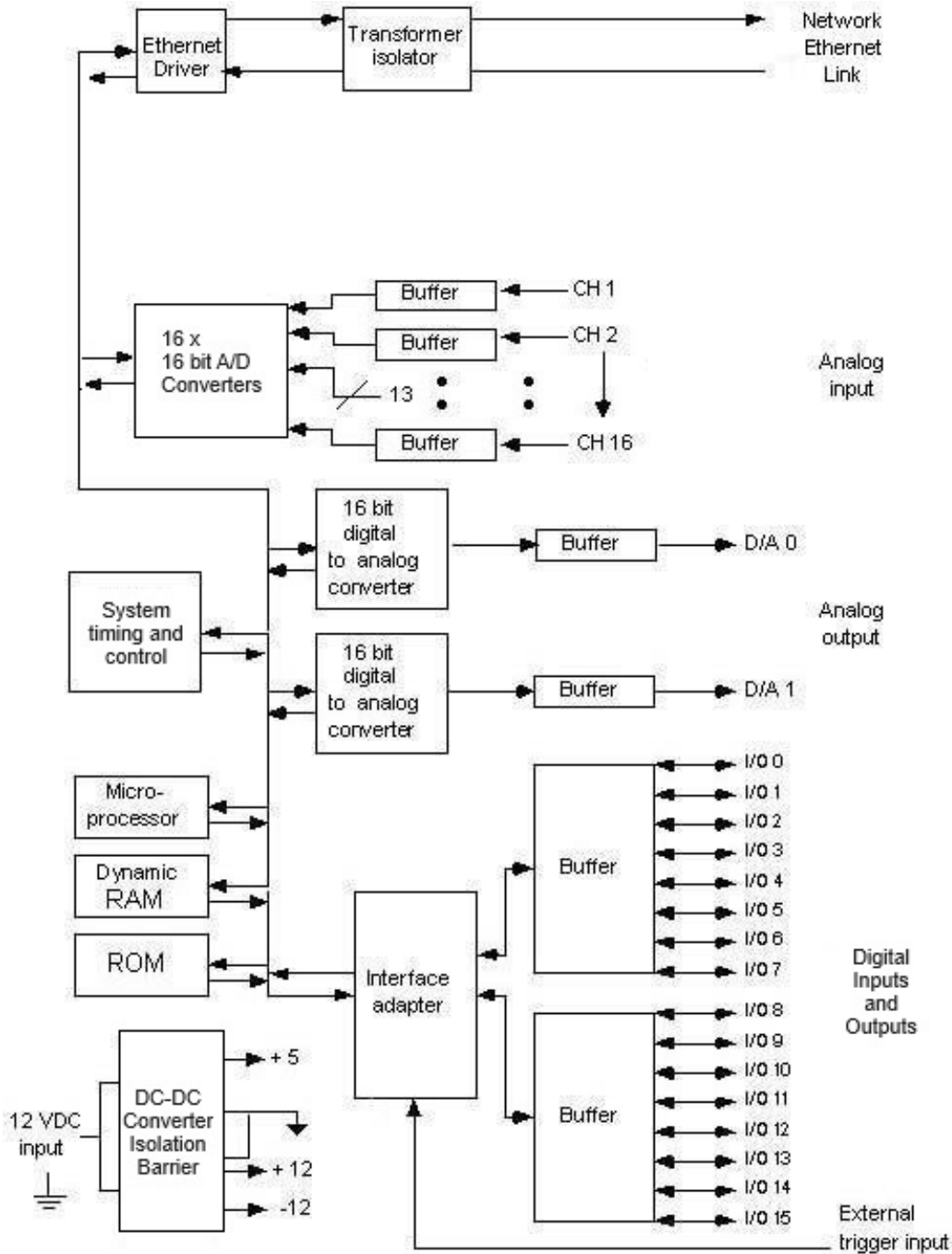

MP200A-CE block diagram

MP SYSTEM PIN-OUTS — FOR MP200

Digital DSUB 25 (male) Pin-outs

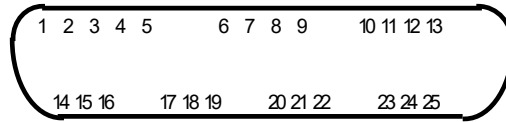

Digital

Pin Description

1 I/O 0	6 GND D	11 I/O 9	16 I/O 6	21 GND A
2 I/O 1	7 EXT T	12 I/O 10	17 I/O 7	22 I/O 12
3 I/O 2	8 +5 VD	13 I/O 11	18 GND A	23 I/O 13
4 I/O 3	9 +5 VD	14 I/O 4	19 Out 1	24 I/O 14
5 GND D	10 I/O 8	15 I/O 5	20 Out 0	25 I/O 15

Analog DSUB 37 (male) Pin-outs

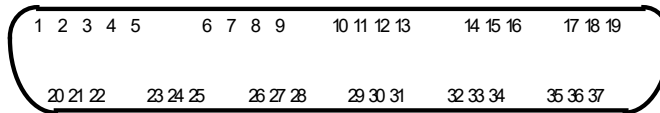

Analog

Pin Description

1 GND A	9 +12 V	17 GND A	25 CH 6	33 CH 12
2 GND A	10 GND A	18 GND A	26 CH 7	34 CH 13
3 GND A	11 -12 V	19 GND A	27 CH 8	35 CH 14
4 GND A	12 GND A	20 CH 1	28 +12 V	36 CH 15
5 GND A	13 GND A	21 CH 2	29 -12 V	37 CH 16
6 GND A	14 GND A	22 CH 3	30 CH 9	
7 GND A	15 GND A	23 CH 4	31 CH 10	
8 GND A	16 GND A	24 CH 5	32 CH 11	

Ethernet connector Pin-outs

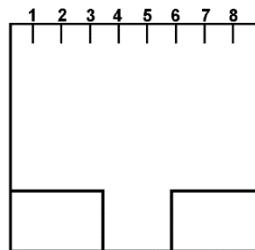

Front View

Pin Description

1 TXD+	3 RXD+	5 No Connection	7 No Connection
2 TXD-	4 No Connection	6 RXD-	8 No Connection